







Quality products. Built to last.



Also available in orange

pro series juicer



- ✓ Compact size — 11 $\frac{3}{4}$ " (30cm) tall, 7 $\frac{1}{2}$ " (19cm) diameter
- ✓ Able to extract up to 10 gallons (37 liters) per hour
- ✓ Quick & easy cleaning, 3 lift-off dishwasher safe parts
- ✓ Quiet, high-torque motor
- ✓ Voltage: AC 115/60, AC 230/50, AC 230/60
- ✓ Proven performance
- ✓ One-year warranty
- ✓ Crafted in the USA     

SUNKIST

Tel: 800.383.7141

Fax: 909.822.2125

10730 Bell Court
Rancho Cucamonga, CA 91730

www.sunkistequipment.com

Sunkist

Pro Series Citrus Juicer Information

Literature Backside

Effective: July 5, 2022

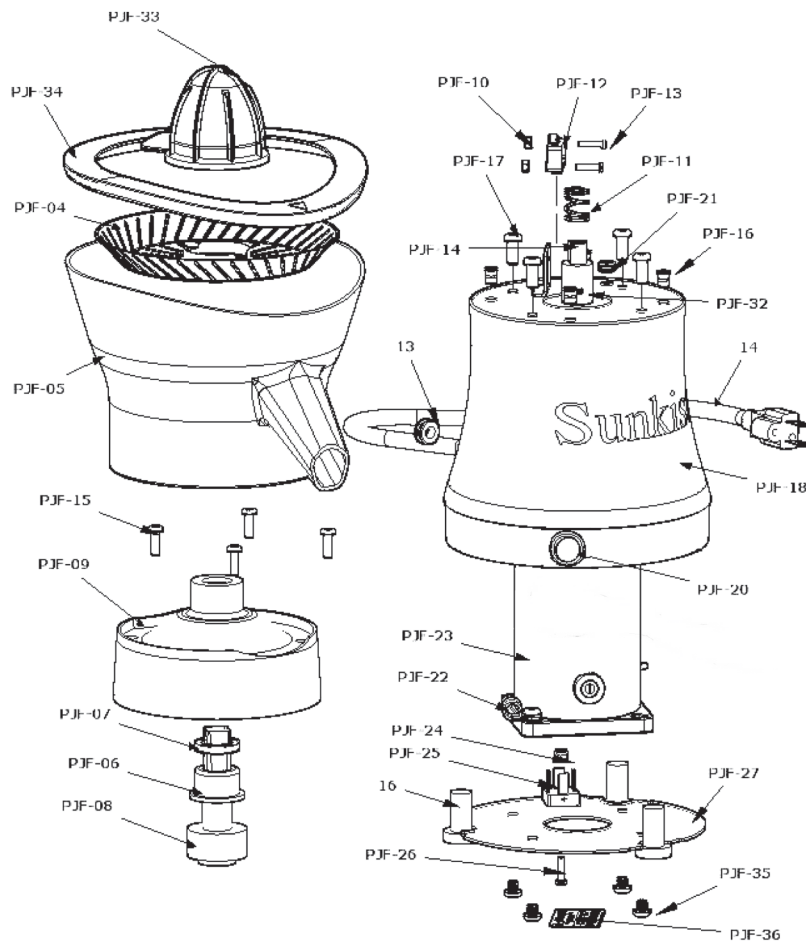

Specifications

- Chrome plated steel housing. Corrosion proof plastic dome, spout & bowl support
- Listed by.....**UL, CUL, CE, CCC, EPH**
- Shipping weight.....13 lbs.
- Net weight.....11½ lbs.
- Overall dimensions.....11¾" tall, 7½" diameter
- Carton size.....9½" W x 9¼" L x 13" H
- Motor.....Hi-Torque 18.9 in-lbs., 900 RPM

All prices quoted are FOB Rancho Cucamonga, CA and are subject to change without notice. These prices are also listed in AutoQuotes. The amount of any present or future tax shall be paid by the purchaser. There is **no** minimum order fee for orders we drop ship to your customer, or for orders being sent to service centers for equipment waiting to be repaired. A service charge of \$10.00 will be added to all orders less than \$50.00 that are shipped to your location or one of your warehouses. CONTACT: Sunkist Foodservice Equipment Customer Service: 800.383.7141. FAX orders to 909.822.2125. **Products must not be returned without a return authorization #.**

www.sunkistequipment.com